

ECU

Filtered Battery Charger/DC Power Supply



Automated smart charger delivers non-stop DC power

- **For critical applications** – energy production, communications, utilities
- **Filtered, battery eliminator output** – delivers stable, smooth DC
- **Precise, temperature compensated charging** – maximizes battery life
- **Digital user interface** – offers easy to understand display and controls
- **Dual Path cooling** – reduces internal temperatures for longest life
- **Hardened design** – resists extreme temperatures and electrical transients



ECU Battery Charger benefits and features



SENS ECU is the core of a high reliability non-stop DC power system.

DC battery systems are vital to mission critical applications such as oil and gas pipelines, electric power distribution and telecommunications. SENS ECU delivers more than just smooth DC power to these vital applications. Together with an appropriate battery SENS ECU creates a highly dependable non-stop DC power system.

ECU makes the most reliable DC power system possible for any given battery. ECU's automated, precise charging includes temperature compensation and overcharge protection to assure correct battery charge even in uncontrolled environments. Battery makers agree that this real-time tailoring of charging characteristics to battery condition is the key to maximum battery performance and life.

ECU delivers high reliability under harsh conditions. EnerGenius® reliability technology includes *Dual Path* convection cooling, generous component de-rating, overtemperature limiting, hardening to electrical transients and fully recessed controls to eliminate damage. Fully independent control, alarm and overvoltage protection systems prevent single point failures.

ECU is easy to understand and use. A comprehensive LCD display presents complete data on charger and battery status, including large digital meters. Two simple knobs operate a variety of adjustments and features. Generous standard equipment includes AC and DC circuit breakers, complete alarms, well-filtered output plus EMC and safety agency compliance.

SENS ECU is the totally automated smart charger that assures highest DC power reliability, even in severe environments.

ECU specifications

AC input, single-phase

Standard input, 60 Hz rating

< 3,500 W output: Field selectable 120/208/240 VAC

≥ 3,500 W output: 240 VAC, 60 Hz

Standard input, 50/60 Hz rating

< 3,500 W output: Field selectable 120/208/220-240 VAC

≥ 3,500 W output: 230 VAC, 50/60 Hz

Optional inputs, 60 Hz

208, 480, 575 VAC, 60 Hz

Optional input, 50/60 Hz

400 VAC, 50/60 Hz

Input voltage selection

Field accessible terminal block

Voltage tolerance

60 Hz: -12%, +6% per NEMA PE-5. 50 Hz: ±10%

Frequency tolerance

±5%

Efficiency

>91%, (120-volt units)

Input protection

2-pole circuit breaker, inrush limiter, soft start, transient suppression

DC output

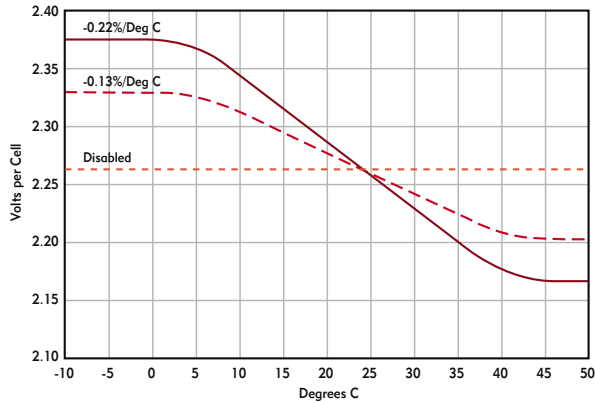

Standard temperature compensation

Chart shows a float setting of 2.26 volts per cell. Users can select either of two generally accepted temperature compensation (TC) curves, or disable TC if desired. The remote TC probe is optional, and can be connected anytime.

Nominal voltage ratings

12, 24, 48, 110, 120, 220 or 240 volts

Typical operating voltage

Typically 10% to 25% above nominal rating, depending on charge mode, battery type and number of cells

Regulation

±0.5% line and load regulation

Current limit

Preset at 105% of rated current and adjustable from 60% to 110%

Charge characteristic

Constant voltage, current limited, multi-rate

Charge mode control

User selectable float, timed equalize or battery-interactive automatic equalize modes

Standard output filtering

12, 24, 48V: 30 mV rms on battery 4 times AH of charger's amp rating; 100 mV rms without battery

110, 120, 220, 240V: 1% rms on battery; 2% w/o battery

Optional output filtering

110, 120, 220, 240V: 30 mV rms on battery; 100 mV rms w/o battery (110, 120 V units); 200 mV rms w/o battery (220, 240 V units)

Dynamic response

On battery, output voltage remains within 5% of initial voltage with step load current change 20% to 100% and 100% to 20%. Recovery to within 1% of steady state voltage within 200 milliseconds.

Battery eliminator operation

Operates in stable fashion without battery. Contact factory for advice on use with constant power loads, such as inverters, without battery

Temperature compensation

Enable or disable. Remote sensor optional. Two slope programs

Reverse polarity protection

Audible warning, internal diode, DC circuit breaker

Parallel operation

Active load share maintains output currents within 10% of each other

Output protection

Current limit, 2-pole circuit breaker, transient voltage suppression

User interface, indication, alarms and controls



Voltmeter display

Ammeter display

Charging mode selector

Equalize timer setting (hours)

Status and alarm indicators

Digital metering	Large digital LCD displays for output volts and amperes, +1% accuracy
Status indication	LCD indicators for AC good, float mode, equalize mode, equalize time remaining, temp comp active, overtemp limiter active
Alarm indications	LCD indicators plus Form C contacts for AC fail, low DC volts, high DC volts, charger fail, overvoltage shutdown, ground fault
Alarm contacts rating	2A at 26 VDC, 0.5A at 120VDC, resistive. Higher current alarm relay optional
Equalize control	Front panel selector for float, automatic or time limited equalize mode. 12 to 72 hour selectable time limit in any equalize mode
System test mode	User selectable exercise of display or remote contacts
Output voltage adjustments	Separately adjustable float and equalize voltages
Low voltage alarm adjustments	3 pre-programmed levels
Overvoltage alarm	11 pre-programmed levels
Selective overvoltage protection	Latching shutdown 4% above overvoltage alarm, transient protected and fully independent of charger control system. In parallel charger systems only the charger responsible for the fault is shut down

Environmental

Operating temperature	-40C to +60C, with full output available to +50C (+45C in 100 and 150A units)
Overtemperature protection	Gradual current reduction to maintain safe power device temperature. Current limit drops to zero amps at about 90C ambient.
Storage temperature	-40C to +85C
Humidity	5% to 95%, non-condensing
Seismic compliance	Tested compliant to UBC Seismic Zone 4
Transient, RF, ESD immunity	To ANSI/IEEE C62.41, Cat. B; ANSI C37.90a; EN50082-2 heavy industrial

Agency compliance

Safety	C-UL listed to UL 1012; CSA standard 22.2 no. 107.2-M89 CE: 50/60 Hz units DOC to EN 60335
Agency marking	60 Hz: C-UL listed 50/60 Hz: C-UL listed plus CE marked
EMI	FCC Part 15 Class A; EN 50081-2
Other	NFPA-110 compliant alarm system NFPA-70 compliant

Mechanical/construction

Housing	CR steel. Cleaned and electroplated, then painted with electrostatically applied and baked polyester compound. Standard wall mounting brackets field configurable for 19" (size E1) or 23" (size E2) relay racks. Brackets reversible for relay rack mounting. Size E2 also available with floor mount brackets
Damage prevention	Fully recessed display and controls. Seismic zone 4 tested
Electrical connections	Compression terminals
Cooling	<i>Dual Path</i> convection cooling delivers unheated air to life-critical components
Printed circuit card	Surface mount technology, conformal coated

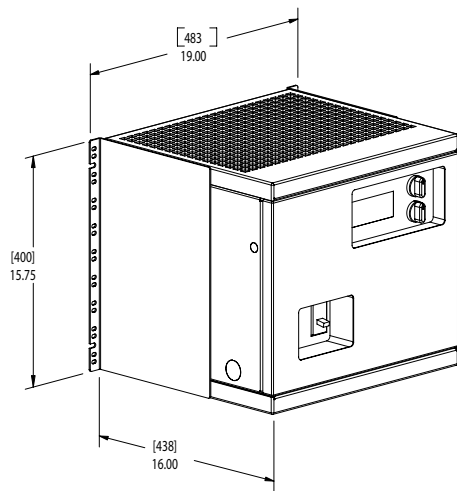

Housing size E1
Wall mount configuration

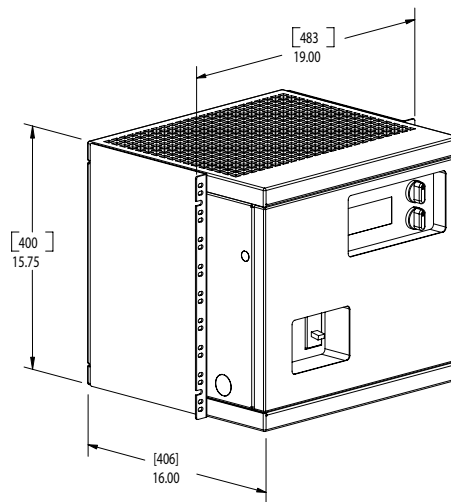

Housing size E1
19" relay rack configuration

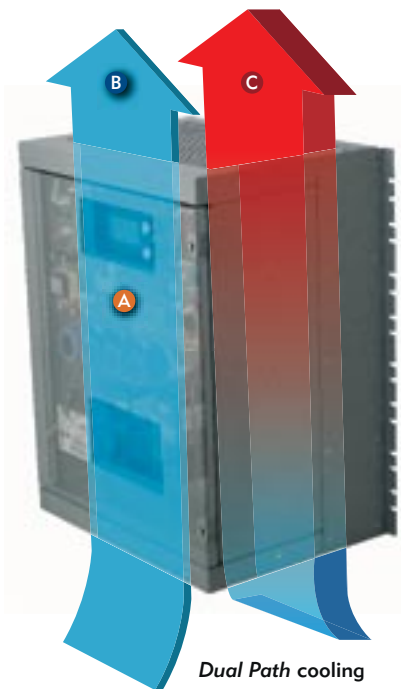

E2 internal construction



E1 external view

Modular design minimizes discrete wiring, increasing reliability

- A** Filter capacitors, circuit boards, breakers isolated from warm magnetics and power semiconductors
- B** Non-heated airflow over filter capacitors, circuit boards and breakers
- C** Generous convective airflow through magnetics and power semiconductors allows operation to +60C
- D** Modular assemblies remove for easy service
- E** Fully recessed controls and breakers prevent damage

Housing dimensions

Housing	Width	Depth	Height
E1 – wall or rack mount	19.00" (483 mm)	16.00" (406 mm)	15.75" (400 mm)
E2 – wall mount	23.00" (584 mm)	16.00" (406 mm)	28.00" (711 mm)
E2 – rack mount	23.00" (584 mm)	15.50" (394 mm)	28.00" (711 mm)
E2 – free-standing	21.20" (538 mm)	15.50" (394 mm)	31.70" (805 mm)

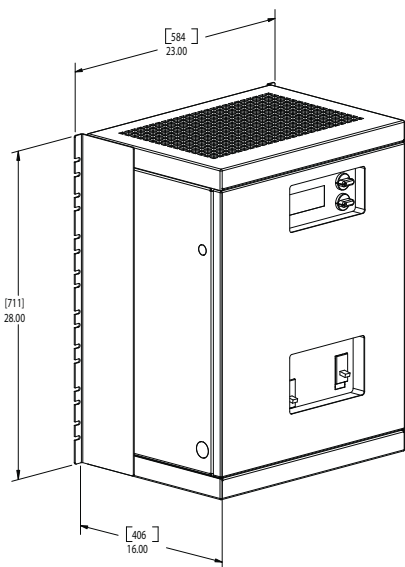

Housing size E2
Wall mount configuration

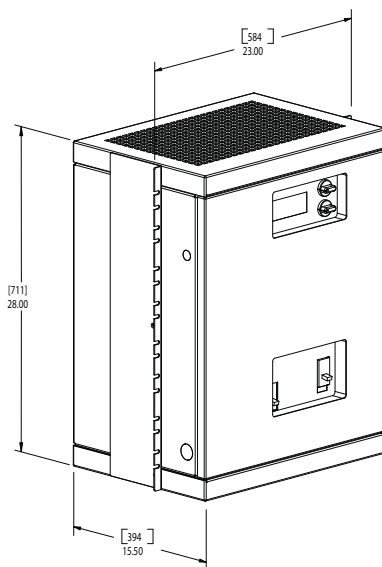

Housing size E2
23" relay rack configuration

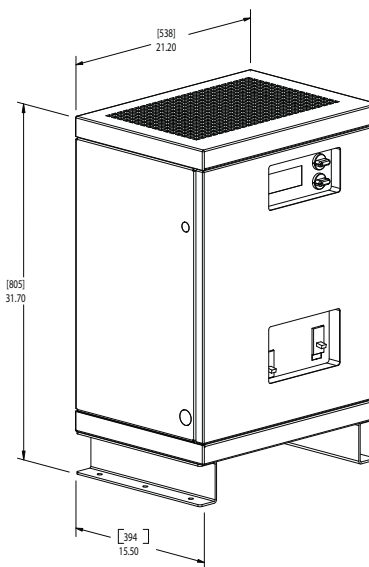

Housing size E2
Free-standing configuration

Optional features

- Input
- High interrupt AC breaker
- Mounting
- Remote temp comp sensor
- Drip shield
- Outdoor cabinet

- Optional input voltages as listed under AC input
- 65 KAIC rating available in most units
- Floor mounting for housing size E2
- Recommended where battery and charger are in different temperatures
- Protects from dripping water to IP22
- Allows placement of charger and/or battery nearly anywhere

